



RACK SAFETY INSPECTION (example)

EXAMPLE REPORT

CONTENTS

1. Storage Equipment Manufacturers Association (SEMA) Guide Lines.
2. Introduction to the Inspection.
3. Components Specification
4. Itemised Inspection.
5. List of material to replace missing or damaged components.
6. General comments, observations and recommendations.
7. Recorded date of repairs.
8. Layout drawing of rack.

1. Storage Equipment Manufacturers Association (SEMA) Guide Lines

The purpose of this report is to provide a comprehensive record of a “Rack Safety Inspection” that was carried out on the 19th January 2006 in the following storage areas:

Main Warehouse

The information contained in this report conforms to the Storage Equipment Manufacturers Association Guide to The Conduct of Pallet Racking and Shelving Surveys.

The SEMA Guide classifies damage into the following three categories :-

RED RISK

These are items which are severely damaged well beyond the limitations of the SEMA Code. In such circumstances, the racking should be immediately **Off-Loaded** and isolated from future use until repair work is carried out.

ORANGE RISK

These items are damaged beyond the limitations of the SEMA Code, but not sufficiently serious to warrant immediate Off-Load of the rack. The rack should be Off-Loaded as soon as possible but normally within 4 weeks, and should not be re-used until repair work is carried out.

GREEN RISK

These are items which are damaged but are within the limitations of the SEMA Code. Such items would be recorded as being still suitable for use but be identified for future reference and monitoring.

A “Serious Damage Report” will have been issued on the day of the inspection for all damage designated RED RISK.

Inspected By: Martin Sawyer

1. Storage Equipment Manufacturers Association (SEMA) Guide Lines continued

Assessment of damage to uprights and bracing members

A steel straight edge 1.0 metre long is placed in contact with a flat surface on the concave side of the damaged member such that the damage area lies central as near as possible to the length of the straight edge.

For an upright bent in the plane of the frame bracing, the maximum gap between the upright and straight edge should not exceed **3mm**.

For an upright bent in the direction of the rack beam spans, the maximum gap between the upright and straight edge should not exceed **5mm**.

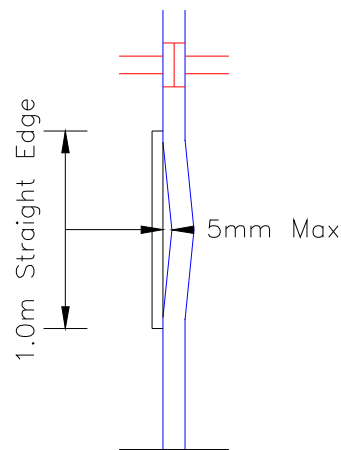
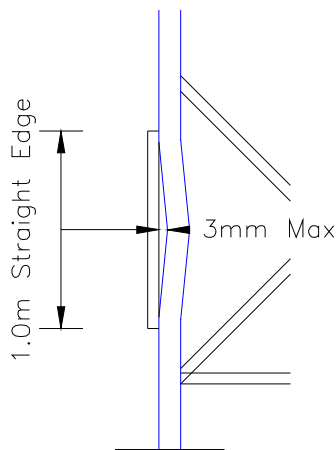

For an upright which has been damaged such that there is a simultaneous bend in both directions, the left to right and front to back deformation shall be measured separately and the appropriate limits observed.

For bracing members bent in either plane, the gap between straight edge and bracing member should not exceed **10mm**.

These rules apply only to damage, which produces an overall bend in a member, they do not apply to highly localised damage such as dents, buckles, tears and splits. Localised bends over a length of less than 1.0m may be judged pro-rata to the above limits. Members subjected to tears and splits should be replaced.

1. Storage Equipment Manufacturers Association (SEMA) Guide Lines continued

Assessment of damage to beams

Beams will naturally deflect under normal loading conditions to a maximum permissible of span/200. This deflection should disappear when beams are unloaded and should not be confused with permanent deformation caused by overloading or impact damage

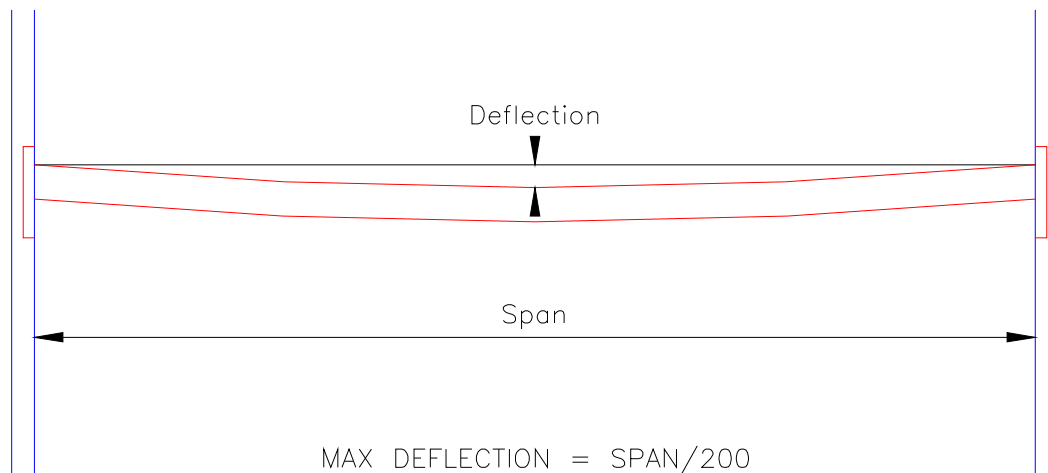

Residual vertical deformation should not exceed 20% of normal deflection under load. Residual lateral deformation should not exceed 40% of the normal vertical deflection under load.

Beams which show any clearly visible deformation to the beam end connectors should be unloaded and replaced.

Beams which show any signs of cracking to the weld between the beam section and end connector should be unloaded and replaced.

2. Introduction to the Inspection

Adjustable Pallet Racking

1. The Inspection took place from ground level.
2. In some instances the rear uprights and frame bracing could not be inspected due to pallet loads being positioned tightly to the frame.
3. Rear beams where visible were inspected.
4. All racking must display Load Notices stating allowable beam and bay loads.
5. All damaged components must be replaced like for like.
6. The free leg length is defined as the distance from the ground to the 1st beam level. This should never be altered from the original design without referring back to the manufacturer/supplier.
7. It is expected that all previous damage repairs have been carried out to the rack manufacturers construction standards and that repairers, sub-contractors or in-house maintenance personnel have been fully trained, preferably SEIRS trained.

3. Components Specification

Main Warehouse

Dexion

Adjustable Pallet Racking

Component	Description
Uprights	“M”, 2435mm full height
Frames	910mm wide, bolted (grey)
Base Plates	Speedlock type
Beams	105mm x 45mm boxed, 2745mm clear entry, 82.6mm drop (orange)
1st Beam	1980mm
Beam Levels	2
Aisle Width	2750mm
Floor Fixings	Front and rear
Column Guards	Floor mounted to some end frames
Load Notices	Max Bay load 2500kgs Max Beam load 2500kgs June 2004 Job Ref 33623

4. Itemised Inspection

Main Warehouse Dexion Adjustable Pallet Racking

Location	Damage	Risk	Action
Rack A			
7	Column Guard Floor Fixing ineffective	Orange	Replace
8	Beam damaged, top	Orange	Replace
15	Floor Fixing loose	Orange	Rectify
18 / 19	Base Plate twisted	Orange	Rectify
20	Horizontal damaged	Green	Note
21	Upright twisted Horizontal damaged (bracing hole elongated) Diagonal damaged (bracing hole elongated)	RED RED RED	Rectify Rectify Rectify
21 / 23	Floor Fixing loose	Orange	Rectify
24 / 26	Base Plate twisted	Orange	Rectify
34	Column Guard damaged	Orange	Replace
Rack B			
2	Column Guard Floor Fixings ineffective x 4	Orange	Replace
4 / 6	Base Plate twisted	Orange	Rectify
16 / 14	Floor Fixing loose	Orange	Rectify
16	Column Guard Floor Fixings ineffective x 4 Base Plate twisted	Orange Orange	Replace Rectify
18	Column Guard damaged and fitted too close Horizontal damaged	Orange Orange	Rectify Replace
24 / 26	Upright twisted	Orange	Rectify
44	Column Guard Floor Fixings loose x 4	Orange	Rectify
46	Column Guard Floor Fixings ineffective x 4 Upright damaged, top Base Plate twisted	Orange Green Orange	Replace Note Rectify
56 / 58	Base Plate twisted	Orange	Rectify
70 / 73	Base Plate twisted	Orange	Rectify

4. Itemised Inspection continued

Main Warehouse

Dexion

Adjustable Pallet Racking

Location	Damage	Risk	Action
Rack B 74	Horizontal damaged	Orange	Replace
B67 / A34	End frame protector recommended	Green	Recommend
67	Column Guard Floor Fixings loose x 2 Base Plate twisted, rear	Orange Orange	Rectify Rectify
71 / 72	Floor Fixing loose	Orange	Rectify
B45 / A21	End frame protector recommended	Green	Recommend
45	Column Guard damaged	Orange	Replace
B43 / A20	End frame protector recommended	Green	Recommend
43	Column Guard Floor Fixings ineffective x 4	Orange	Replace
35 / 37	Levelling Plate not seated	Orange	Rectify
27 / 29	Base Plate twisted	Orange	Rectify
19 / 21	Base Plate twisted	Orange	Rectify
B17 / A8	End frame protector recommended	Green	Recommend
17	Column Guard Floor Fixings sheared or ineffective x 4	Orange	Replace
B15 / A7	End frame protector recommended	Green	Recommend
15	Column Guard Floor Fixing ineffective	Orange	Replace
7 / 9	Diagonal damaged Base Plate twisted	Orange Orange	Replace Rectify
3 / 5	Floor Fixing sheared Upright twisted Column Guard Floor Fixing ineffective	Orange Orange Orange	Replace Rectify Replace

4. Itemised Inspection continued

Main Warehouse

Dexion

Adjustable Pallet Racking

Location	Damage	Risk	Action
Rack C			
2	Upright twisted Column Guard poorly fitted	Orange Orange	Rectify Rectify
12 / 14	Upright damaged at base	Green	Note
16	Column Guard Floor Fixings loose x 2	Orange	Rectify
18	Horizontal damaged Diagonal damaged Upright twisted, rear Column Guard Floor Fixing sheared	Orange Orange Orange Orange	Replace Replace Rectify Replace
24 / 26	Upright twisted	Orange	Rectify

5. List of material to replace missing or damaged components.

Main Warehouse

Dexion

Adjustable Pallet Racking

Replace Component	Description	Quantity
Floor Fixing Bolts	For Column guards	33
	For Uprights	7
Beams	105mm x 45mm boxed, 2745mm clear entry 82.6mm drop (orange)	4
Uprights	“M”, 2435mm full height	2
Horizontals	910mm wide frames, bolted (grey)	9
Diagonals	910mm wide frames, bolted (grey)	5
Column Guards	Floor mounted	6
Recommend Component	Description	Quantity
End Frame Protectors	Double entry width, to replace column guards	22
Rectify Component	Description	Quantity
Floor Fixing Bolts	Loose (uprights)	9
	Loose (column guards)	18
Base Plates	Twisted	27
Uprights	Twisted	20
Column Guards	Reposition further away from uprights	5
Levelling Plates	Not seated	4

6. General comments, observations and recommendations.

Column Guards : Although protecting uprights from minor damage, upright mounted column guards sometimes hide more serious damage. Damaged upright mounted column guards should be removed so that the upright can be checked for damage. Upright mounted column guards must not be fitted to already damaged uprights. Floor mounted column guards are ineffective if positioned too close to the upright.

"Like for Like" replacements: As previously explained in this report, the SEMA guide lines clearly state that all damaged material must be replaced "like for like". It has been noted in this report where a "Dexion" upright has been replaced with a "Ramada" upright. Technically this currently falls outside of the SEMA code. However, as it is now not always possible to source new replacement "Dexion" materials, suppliers are turning to alternative manufacturers for these replacement items. It therefore becomes the responsibility of the supplier to ensure the structural compatibility of this alternative replacement material. The client should ensure that the supplier has sought and obtained assurances as to the compatibility of these replacement items from the manufacturer.

Ramada Uprights : Unlike Dexion uprights, Ramada uprights are not reversible. The beam connector slots only function correctly when the upright is positioned the correct way up. The replacement of uprights with upside down Ramada uprights is a serious issue and should be corrected immediately. The installers should be informed of this in order to ensure that there is no repetition.

Load Notices : These should be displayed on all racking and shelving. They should be placed in a prominent location on or adjacent to the equipment so that they are clearly visible. The information displayed should as a minimum indicate the maximum allowable beam/shelf/bay/pallet loads. The new SEMA guidelines require that additional information relating to the height of the first beam level and the beam pitch also be displayed. It is recommended that all load notices are replaced to this standard. A load notice is required at the entry into any storage area. Different configurations of racking or shelving within an aisle will require more than one load notice to be displayed.

Frame Bracing : The importance of bracing is sometimes underestimated. Frame bracing can help to reduce impact damage to uprights. Frames must be braced to the manufacturers standards. A number of frames have been installed the wrong way around with the base diagonal pointing to the inside of the rack rather than the outside. The client should seek assurances from the supplier/installer that this is acceptable and that this does not affect the load carrying capacity of the rack.

End Frame Protection : It is recommended that rack end protectors are fitted to the ends of rack runs to provide protection against impact damage. The existing column protection is suffering considerable damage.

The SEMA guide recommends that in addition to an annual inspection by a "Technically Competent Person", regular (weekly) visual checks should be made by a designated person on site. Warehouse operatives should also be encouraged to report any damage as it occurs.

The client should be aware of the relevant **Health & Safety** guidelines, such as "HS(G)76 Health & Safety in Retail & Wholesale Warehouses".

The client should be familiar with the requirements of "The Provision and Use of Work Equipment Regulations (PUWER) 1998".

6. Recorded date of repairs

Comments

Date of Repairs

.....

.....

.....

.....

.....

.....

.....

.....